

Grill Station

The modern, stylish Roband Grill Station is now available in six or eight slice size models. The latest addition to the Roband range sets the benchmark for commercial contact grills. The versatile unit rapidly toasts sandwiches, paninis and focaccias, in addition to producing beautifully seared and grilled tender meat, poultry and fish.

Featuring elements embedded directly into smooth, high pressure die-cast aluminium plates, the cooking surface produces an even, extremely efficient heat transfer ensuring food is cooked rapidly with even colouration.

The Roband Grill Station truly is a must-have for cafes, takeaways, sandwich shops or anywhere that toasting and/or grilling is required.



GSA810S pictured

FEATURES

- Six or eight sandwich capacity
- Quality high pressure die-cast aluminium cooking plates with cast-in elements for efficient, directional and effective heat transfer
- Precise thermostat for controlling cooking temperature
- Even temperature distribution across each plate and between the top and bottom plates
- Ability to switch between top and bottom plate operation or bottom plate only operation
- A counter-balanced top plate and an arched handle makes operating the Grill Station easy
- Easy one-handed loading and unloading of food with the top plate capable of staying partially open at an approximate 45° angle
- A load limiter that reduces the resting weight of the top plate on food being grilled or toasted
- High splash guard with top plate always positioned over bottom plate ensuring grease and crumbs fall onto bottom plate
- A front positioned grease collection box collects grease and crumbs and is well-positioned for easy removal and cleaning
- Small counter space requirement due to the elimination of a cumbersome back cable
- Angled control panel for clear visibility of settings
- 5 minute timer with warning bell
- Optional ribbed top plate and/or non-stick coating
-  Advanced Control Safety Systems

Grill Station

FEATURES & OPTIONS FOR ALL GRILL STATIONS

Smooth plates
Non-stick coated

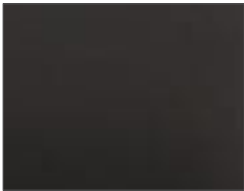

Ribbed top plate
Non-stick coated



Smooth plates



Ribbed top plate

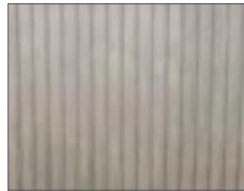

Top plate props open for easy access to food

GSA610S pictured

Plate options



Top plate always positioned over bottom plate

High splash guard



Removable grease tray

Top & bottom or bottom only plate selection

Thermostat control

Timer

No cumbersome back cable,
reducing counter space needed



Grill Station

SPECIFICATIONS

MODEL	SLICES No.	PLATE COATING	TOP PLATE	POWER Watts	ELEC CON. Amps	DIMENSIONS w x d x h (mm)	BOTTOM PLATE DIMENSIONS w x d (mm)
GSA610S	6	NIL	SMOOTH	2200	10	435 x 490 x 220	375 x 275
GSA610R	6	NIL	RIBBED	2200	10	435 x 490 x 220	375 x 275
GSA610ST	6	NON-STICK	SMOOTH	2200	10	435 x 490 x 220	375 x 275
GSA610RT	6	NON-STICK	RIBBED	2200	10	435 x 490 x 220	375 x 275
GSA810S	8	NIL	SMOOTH	2300	10	560 x 490 x 220	500 x 275
GSA810R	8	NIL	RIBBED	2300	10	560 x 490 x 220	500 x 275
GSA810ST	8	NON-STICK	SMOOTH	2300	10	560 x 490 x 220	500 x 275
GSA810RT	8	NON-STICK	RIBBED	2300	10	560 x 490 x 220	500 x 275
GSA815S	8	NIL	SMOOTH	2990	15	560 x 490 x 220	500 x 275
GSA815R	8	NIL	RIBBED	2990	15	560 x 490 x 220	500 x 275
GSA815ST	8	NON-STICK	SMOOTH	2990	15	560 x 490 x 220	500 x 275
GSA815RT	8	NON-STICK	RIBBED	2990	15	560 x 490 x 220	500 x 275

Note: All bottom plates are smooth. Timer does not over-ride or control thermostat. Maximum height when top fully open is 580 mm.

DIMENSIONS - ALL 6 SLICE MODELS

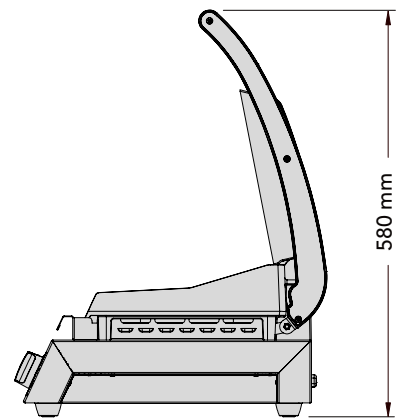
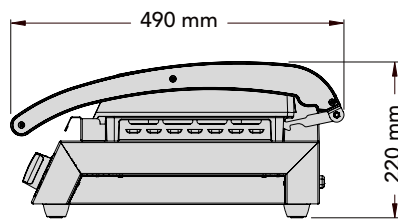
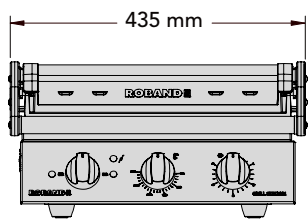

DIMENSIONS - ALL 8 SLICE MODELS

